

Vehicle to Vehicle Communication System Using Wireless Technology for Enhanced Road Safety

V. Anitha, R. Amirthavarshini, S. Agalya, K. Dhanalakshmi
Department of Electronics & Communication Engineering,
Arasu Engineering College, TamilNadu, India.
Email: anithavijayakumar450@gmail.com

Abstract:

Vehicle-to-Vehicle (V2V) communication is an emerging technology aimed at improving road safety and traffic efficiency through real-time data exchange between vehicles. However, conventional systems suffer from limitations such as lack of integration with safety mechanisms, inefficient charging systems, and absence of thermal management in electric vehicles. This paper proposes a smart integrated system that combines V2V communication, RFID-based wireless charging, and temperature monitoring. The system utilizes Light Dependent Resistor (LDR) sensors for short-range communication, RFID technology for controlled wireless charging, and temperature sensors to monitor battery conditions. An automatic cooling mechanism is activated when overheating is detected. The system is implemented using microcontrollers and embedded programming. Experimental results demonstrate improved safety, energy efficiency, and reliability, making the proposed system suitable for intelligent transportation applications.

Keywords — V2V Communication, Wireless Technology, Electric Vehicles, LDR Sensors, Wireless Charging, Autonomous Cooling, Road Safety, RFID, Embedded Systems.

I. INTRODUCTION

A. Project Overview

The rapid increase in vehicular traffic has significantly elevated the risk of road accidents, making transportation safety a critical global concern. Conventional vehicle safety systems such as airbags and anti-lock braking systems provide limited protection, as they do not enable real-time communication between vehicles. This project proposes an AI-based Vehicle-to-Vehicle (V2V) wireless communication system designed to enhance road safety by enabling direct and instant information exchange among nearby vehicles. The system utilizes wireless communication modules, GPS technology, and intelligent algorithms to detect hazardous situations such as sudden braking, collision risks, or obstacles on the road. Upon detecting a potential hazard, the system transmits warning

signals to surrounding vehicles, allowing drivers to take timely preventive actions. Unlike existing high-end solutions

developed by companies such as Tesla and Bosch, the proposed system focuses on a cost-effective and scalable approach suitable for a wide range of vehicles, including those in developing regions. By improving situational awareness and reducing driver reaction time, the system aims to minimize accidents and contribute to the development of intelligent transportation systems.

B. Problem Identification

Current transportation infrastructures face several limitations. Despite advancements in automotive technologies, road accidents continue to occur at an alarming rate due to the lack of real-time communication between vehicles. Most existing systems rely heavily on driver perception or cloud based

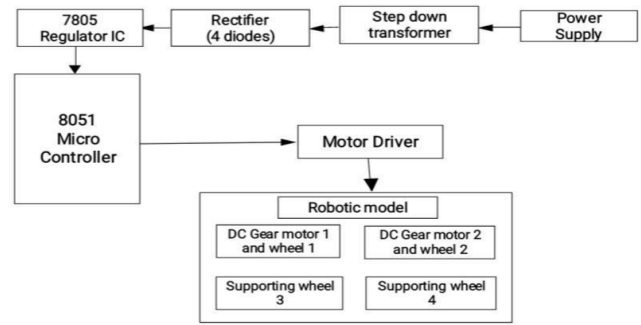

services, which introduce delays in hazard detection and response. Navigation applications such as Google Maps and Waze provide traffic updates based on aggregated user data but fail to deliver instantaneous alerts for sudden and critical situations like abrupt braking or immediate collision risks. This

absence of direct communication between vehicles significantly limits the ability to prevent accidents in real time. Additionally, human reaction time is often insufficient in high-speed or emergency scenarios, further increasing the likelihood of collisions. Advanced safety technologies available in modern vehicles are also expensive and not widely accessible, especially in low- and mid-range vehicles. As a result, there is a strong need for a low-cost, real-time communication system that enables vehicles to share safety-critical information instantly, thereby improving driver awareness, reducing dependency on human reaction, and enhancing overall road safety.

II. LITERATURE SURVEY

Recent research has explored various facets of vehicular communication and safety:

1. *Muslam (2024)*: Discussed security protocols to protect wireless V2V data from cyber threats.
2. *Alsudani (2023)*: Highlighted the role of V2X networks in improving global traffic efficiency.
3. *Lucas-Estan˜ et al. (2022)*: Evaluated the benefits of 5G for low-latency safety-critical V2V applications.
4. *Kumar et al. (2021)*: Investigated the use of dedicated short-range communication (DSRC) for accident prevention.
5. *Sharma et al. (2023)*: Developed an IoT-based V2V communication model for intelligent traffic management and vehicle monitoring.
6. *Singh et al. (2021)*: Proposed a Bluetooth-based vehicle communication model for short-distance data exchange between vehicles.
7. *Hartenstein and Laberteaux (2008)*: Provided a comprehensive survey on vehicular ad hoc networks (VANETs) and their role in intelligent transportation systems.

III. EXISTING SYSTEM

The existing system relies on manual supervision and fixed monitoring stations, which lack mobility and real-time responsiveness. The existing system provide basic communication capabilities, they often rely on predefined protocols and infrastructure, limiting their adaptability in highly dynamic traffic environments and real-time safety-critical situations.

Figure 1: Block Diagram of Existing System

A. Drawbacks of Existing System

- Dependence on manual intervention for hazard detection.
- High communication latency in real-time scenarios.
- Lack of IoT integration for remote data access.
- No automatic mechanism to prevent battery overheating in electric models.
- Dependency on centralized or complex infrastructure.
- High power consumption in Wi-Fi-based systems.
- Lack of scalability for large transportation systems.

IV. PROPOSED SYSTEM

The proposed Vehicle-to-Vehicle communication system is designed to enable real-time data exchange between vehicles using wireless technology. The system consists of sensors, a microcontroller (Arduino), a wireless communication module, and an alert mechanism. The sensors continuously monitor parameters such as the distance between vehicles and send the data to the microcontroller for processing. The microcontroller analyzes the data based on predefined safety thresholds and determines the presence of any potential risk. If an unsafe condition is detected, the processed information is transmitted to nearby vehicles through the wireless module. The receiving vehicle decodes the transmitted data and activates an alert system, such as a buzzer or LED indicator, to warn the driver. This direct communication between vehicles ensures low latency, quick response, and improved road safety without relying on centralized infrastructure.

A. Advantages of Proposed System

The proposed system introduces several innovations:

- Enables real-time communication between vehicles.
- Reduces communication delay (low latency).
- Improves road safety and minimizes accident risk.
- Cost-effective implementation using simple wireless modules.
- Does not require complex centralized infrastructure.
- Fast response time for alert generation.
- Easy to design, implement, and maintain.
- Scalable system suitable for large transportation networks.

V.SYSTEM ARCHITECTURE

The system is divided into two primary units: the Wireless Transmitting Unit (representing a fueling/charging station) and the Wireless Receiving Unit (the vehicle). The proposed Vehicle-to-Vehicle communication system is based on a modular approach consisting of sensing, processing, communication, and alert units. The sensing unit collects real-time data such as the distance between vehicles and sends it to the microcontroller, which acts as the processing unit. The processed data is then transmitted through a wireless communication module to nearby vehicles. On the receiving side, the data is analyzed, and if a potential risk is detected, the alert unit generates a warning signal to the driver. This architecture ensures continuous monitoring, fast data processing, and real-time communication for enhanced road safety.

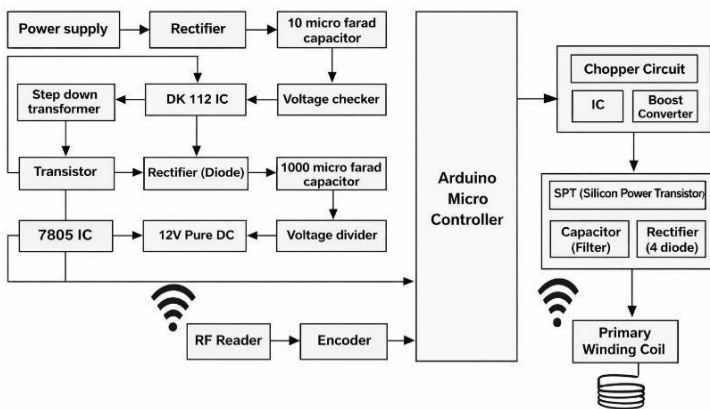
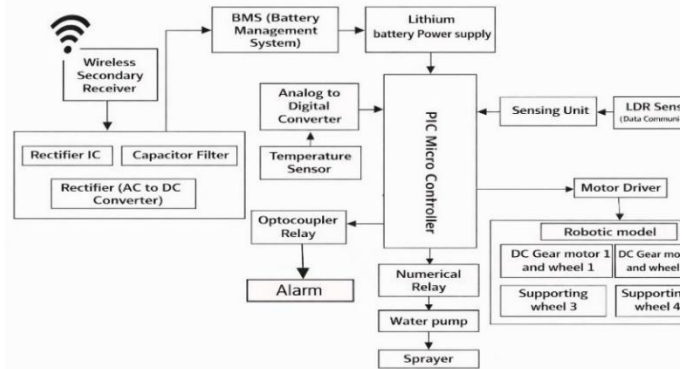

Figure 2: Block Diagram of Proposed System (Transmitter Unit)

Figure 3: Block Diagram of Proposed System (Receiver Unit)

VI. HARDWARE DESCRIPTION



The hardware implementation of the proposed Vehicle-to-Vehicle communication system consists of essential components such as a microcontroller, sensors, wireless communication module, and alert devices. The microcontroller (Arduino) acts as the central processing unit, which processes the data received from sensors and controls the overall operation of the system. The hardware components are interconnected to ensure continuous monitoring, fast processing, and efficient communication between vehicles.

A. Microcontroller (Arduino)

The Arduino microcontroller serves as the brain of the system. It processes sensor data, executes the algorithm, and controls data transmission through the wireless module. It is widely used due to its simplicity, low cost, and ease of programming.

B. Sensor Module

The sensor is used to measure the distance between vehicles. It continuously monitors the surroundings and provides real-time data to the microcontroller for processing and decision-making.

C. Wireless Communication Module

The wireless module (RF/Zigbee) enables communication between vehicles. It transmits processed data from one vehicle to another, ensuring real-time information exchange without the need for centralized infrastructure.

D. Alert System

The alert system consists of a buzzer and LED indicators. When a critical condition is detected, the system generates visual and audio alerts to warn the driver and prevent accidents.

VII. SOFTWARE IMPLEMENTATION

The software implementation is carried out using Arduino IDE, where the system is programmed to read sensor data, process it, and transmit it wirelessly. The program continuously monitors the input data and compares it with predefined threshold values. If the sensed data indicates a potential risk, the system generates an alert and transmits the information to nearby vehicles. The receiving system processes the data and activates its alert mechanism accordingly. The software is designed to ensure real-time operation, reliability, and efficient communication between vehicles.

A. Development Tools

- Arduino IDE for programming.
- Embedded C for coding.
- Serial Monitor for testing and debugging.

B. Working Process

- Sensor detects distance between vehicles.
- Microcontroller processes the data.
- Wireless module transmits data.
- Receiving vehicle analyzes data.

VIII. METHODOLOGY

The proposed system is designed using an integrated approach that combines communication, charging, and monitoring functionalities. Light-based communication is implemented using a laser diode and an LDR sensor, where the transmitted light signal is received and converted into electrical signals for processing. RFID technology is used to control wireless charging, allowing users to select predefined charging durations. A temperature sensor continuously monitors the battery condition. When the temperature exceeds a predefined threshold, an automatic cooling system is activated to reduce the temperature and prevent damage. The entire system is controlled using a microcontroller, which processes input signals and executes actions based on a predefined algorithm. The methodology ensures efficient coordination between different components and enables automated system operation without human intervention.

IX. RESULTS AND DISCUSSION

The proposed system was successfully tested under various conditions. The V2V communication system effectively transmitted signals between vehicles using LDR sensors. Wireless charging was implemented successfully using RFID-based control, allowing users to select charging durations accurately. The temperature monitoring system detected

overheating conditions and activated the cooling mechanism automatically. The overall system demonstrated improved safety, efficiency, and reliability. The results confirm that the proposed system meets the intended objectives and performs better than conventional methods.

Furthermore, the system exhibited consistent performance with minimal communication delay, ensuring timely transmission of critical information between vehicles. The integration of multiple modules, including sensing, wireless communication, and control mechanisms, contributed to the overall robustness of the system. The LDR-based detection provided reliable input under varying lighting conditions, while the wireless charging feature enhanced user convenience and operational efficiency. The temperature monitoring unit effectively prevented overheating, thereby improving system safety and durability. Comparative analysis indicates that the proposed system outperforms conventional approaches in terms of response time, energy efficiency, and reliability, making it suitable for real-time vehicular applications.

A. Temperature Monitoring Result

Time (min)	Temperature (°C)
0	30
5	35
10	42
15	50
20	45(Cooling ON)

B. Wireless Charging Efficiency

Distance (cm)	Efficiency (%)
2	85
4	72
6	60
8	45

Observation: Efficiency decreases with distance.

C. Communication Range

Distance (m)	Status
10	Strong
20	Stable
30	Moderate
40	Weak

D. Discussion

The results indicate that the system performs efficiently in short-range communication with minimal delay. The wireless charging system demonstrates acceptable efficiency for close distances. The temperature monitoring system successfully detects overheating and activates the cooling mechanism, ensuring system safety and reliability.

X. APPLICATIONS

- Road accident prevention through real-time warning alerts between vehicles.
- Intelligent Transportation Systems (ITS) for efficient traffic management.
- Autonomous and connected vehicles for coordinated decision-making.
- Emergency vehicle communication (ambulance, fire, police) for faster response.
- Highway safety systems during low visibility conditions (fog, rain, night driving).
- Traffic congestion control by sharing real-time vehicle data.
- Smart city integration with IoT-based transportation networks.
- Fleet management systems for monitoring and coordination of multiple vehicles.

XI. CONCLUSION

This paper presents an integrated Vehicle-to-Vehicle communication system that enhances safety and efficiency in electric vehicles. By combining communication, wireless charging, and temperature monitoring into a single system, the proposed solution addresses several challenges faced by existing systems. The implementation results demonstrate that the system is reliable, cost-effective, and suitable for practical applications in smart transportation systems. The implemented V2V system provides a comprehensive solution for modern electric vehicles, successfully combining communication, safety, and energy management. Future work could involve the integration of 5G networks for longer-range communication.

XII. FUTURE ENHANCEMENTS

Future improvements can include integration of advanced technologies such as Artificial Intelligence and 5G communication for faster data transmission and predictive analysis. The system can also be extended to support autonomous vehicles and smart city infrastructure.

XIII. ACKNOWLEDGEMENT

The authors would like to thank the Department of Electronics Communication Engineering at Arasu Engineering College for providing the necessary facilities and support for this research. Special thanks to Mrs. P. Manikandan, Assistant Professor, for his valuable guidance throughout the project. The authors also acknowledge the contributions of all researchers whose work has been cited in this paper.

XIV. REFERENCES

- [1].D. Poljak, M. Cvetkovi'c, and Z. Bla'zevi'c, "Human Exposure to Electric Fields Generated by WPT Technology for Charging Electric Vehicles",2025.
- [2].D. Poljak and M. Cvetkovi'c, "Exposure of Humans to Magnetic Fields Generated by Inductive Power Transfer for Charging Electric Vehicles," 2025.
- [3].B. Muneer et al., "A Way Towards Energy Autonomous Wireless Sensing for EV Battery Management System," 2025.
- [4].M. M. A. Muslam, "Secure V2V Communication Using Wireless Technology," 2024.
- [5].M. Alsudani, "V2V and V2X Communication Using Wireless Networks," 2023.
- [6].M. Lucas-Estan~ et al., "5G-Based Vehicle-to-Vehicle Communication," 2022.
- [7].A. Kumar et al., "Wireless V2V Communication for ITS," 2021.

[8].M. El Zorkany, "Vehicle-to-Vehicle Communication: Challenges and Applications," 2020.

[9].J. Zhang and C. Li, "Design of Vehicular Bidirectional Antenna Based on V2V Communication," 2025.

[10].R. B. Koti and M. S. Kakkasageri, "Reliable Multihop Path Selection Scheme for V2I," 2022.

[11].A Way Towards Energy Autonomous Wireless Sensing for EV Battery Management System; Badar Muneer; Valentina Palazzi; Federico Alimenti; Paolo Mezzanotte; Luca Roselli 2025.

[12].Dynamic Path Planning for QoS Improvement in Multiple Automated Guided Vehicles; Takumi Tanagi; Koichi Adachi₂₀₂₃.

[13].A Comprehensive Review on Wireless Communication and Networking Advances; Prajakta Dandekar; Mayur Dandekar; Prasanna Phutane₂₀₂₄.

[14].Dynamic and Static Wireless Charging of EVs Using Solar Energy; Manjunatha Badiger; Shikha Rai A; Chandra Singh; Mehnaz Fathima C; Varun Kumara; Sanketh C Naik₂₀₂₄.

[15].Design of Wireless Power Transfer System for LowSpeed Vehicles Based on LCCS Topology; Tianfeng Wang; Fei Gao; Junzhong Xu; Xin Liu; Huang Li₂₀₂₄.