

Design and Implementation of Wireless Railway Gate Control System with Obstacle Detection and Train Communication

1. K.S.Preethi, Department-Ece, University/College-AAMEC, and Place- Thiruvarur(dt),Kovilvenni-614 403
Email: preethikarthi008@gmail.com
2. P.Pavithra, Department-Ece, University/College-AAMEC, and Place-Thiruvarur(dt),Kovilvenni-614 403
Email: gurupavi445@gmail.com
3. S.Prathiba, Department-Ece , University/College-AAMEC, and Place- Thiruvarur(dt),Kovilvenni-614 403
Email: prathiba312005@gmail.com

Abstract:

This paper presents a wireless railway gate control system with obstacle detection aimed at improving safety at railway level crossings. The system uses RF communication between a train unit and a gate control unit to automate gate operations. When a train approaches, a signal is transmitted to close the gate automatically, and it reopens after the train passes. The system also incorporates obstacle detection to prevent accidents caused by vehicles or pedestrians stuck on the track. This automated solution reduces human error, ensures timely operation, and enhances overall railway safety.

Keywords: Railway Automation, RF Communication, Obstacle Detection, Arduino, Safety System

1. Introduction

Railway level crossings are critical points where road and rail traffic intersect, often leading to accidents due to human error and delayed gate operations. Traditional manual gate systems rely

heavily on human coordination, which may result in unsafe conditions. To overcome these challenges, an automated system is required to ensure timely gate control and prevent accidents. This paper proposes a wireless railway gate control system that uses RF communication and obstacle detection to improve safety and efficiency.

2. Proposed System

The proposed system consists of two main units:

1. Train Unit (Transmitter)
2. Gate Control Unit (Receiver)

The train unit sends a signal using an RF transmitter when it approaches the crossing. The gate control unit receives this signal and activates the gate mechanism using a microcontroller. A motor is used to open and close the gate automatically. Additionally, an obstacle detection mechanism ensures that the gate does not close if any object is detected on the track.

Components Used:

- Arduino Microcontroller
- RF Transmitter & Receiver
- Motor / Servo Motor
- Power Supply
- Ultrasonic Sensor

3. Methodology

Working Process:

1. Train Detection (Entry):
Sensors placed at a distance from the gate detect the approaching train and generate a signal.
2. Signal Transmission:
The detected signal is transmitted wirelessly (RF/ZigBee) to the gate control unit.
3. Signal Processing:
The microcontroller receives and processes the signal to initiate gate operation.

4. Gate Closing Operation:
The motor driver is activated to close the railway gate automatically.
5. Warning Indication:
Buzzer and LED indicators are turned ON to alert vehicles and pedestrians.
6. Obstacle Detection:
Ultrasonic/IR sensors continuously monitor for obstacles on the track during gate closure.
7. Safety Control:
If any obstacle is detected, the system stops the gate movement and triggers an alert.
8. Train Exit Detection:
After the train passes, the exit sensor detects the departure and sends a signal.
9. Gate Opening Operation:
The control unit processes the exit signal and opens the gate automatically.
10. System Reset:
The system returns to its initial state, ready for the next train detection

4. System Design

4.1 Block Diagram

The block diagram below illustrates the overall system architecture, showing the Train Unit (Transmitter) on the left and the Gate Control Unit (Receiver) on the right, communicating via a 433 MHz RF wireless signal.

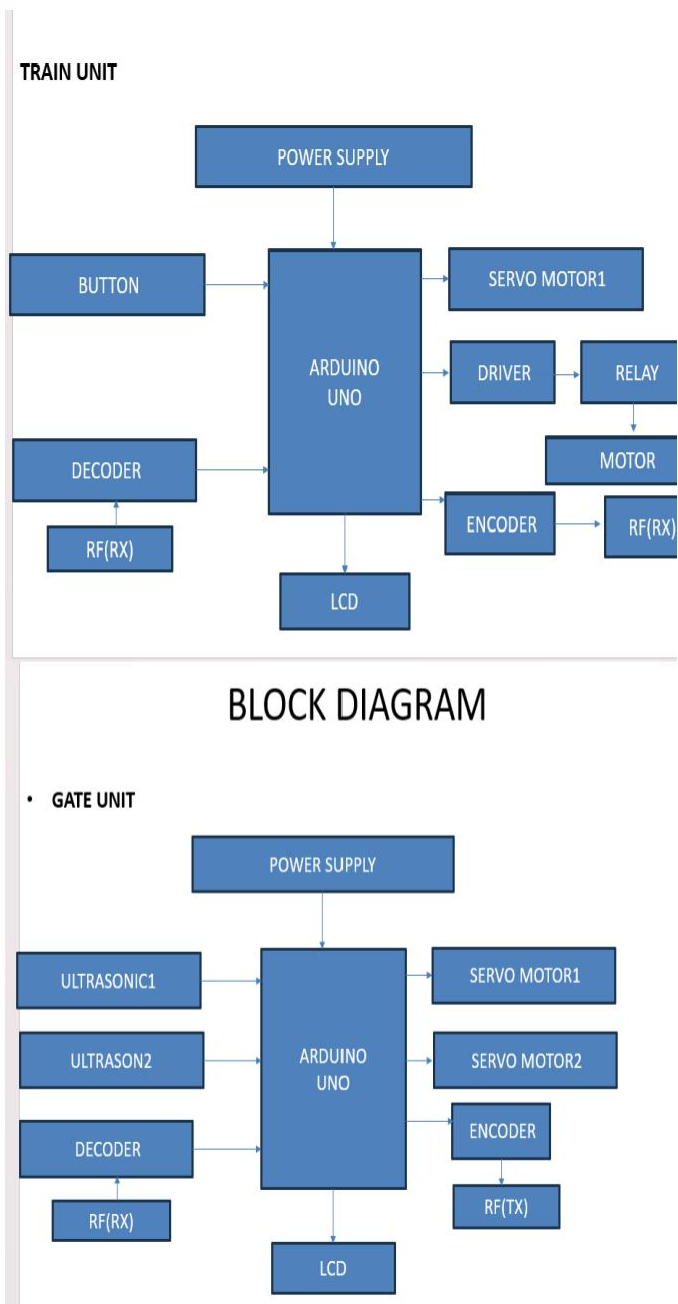
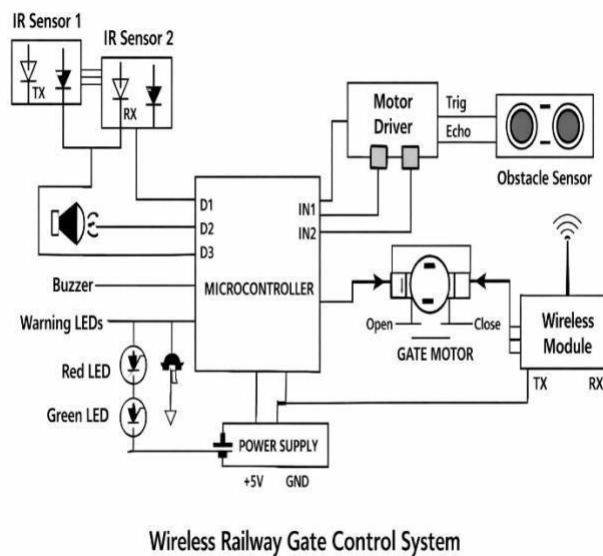

Fig. 1: Block Diagram — Wireless Railway Gate Control System

4.2 Circuit Diagram

The circuit diagram details the pin-level connections of the Arduino UNO with the RF module, IR obstacle sensor, servo motor, LCD display, and power supply.

Fig. 2: Circuit Diagram — Arduino UNO Pin Connections



4.3 System Flowchart

The flowchart describes the complete decision logic of the system from initialization through train detection, obstacle checking, gate control, and continuous loop monitoring.

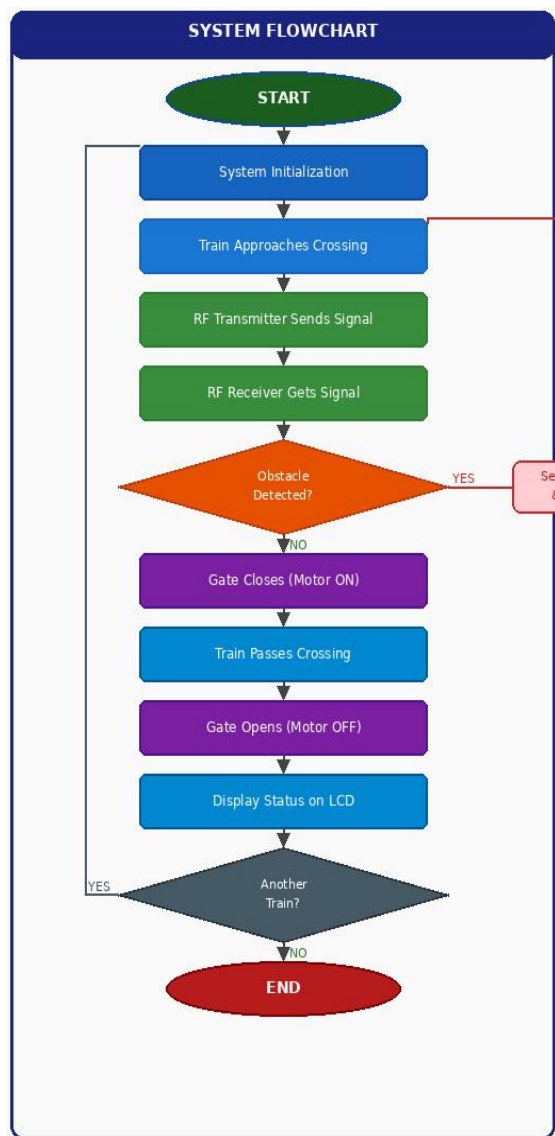
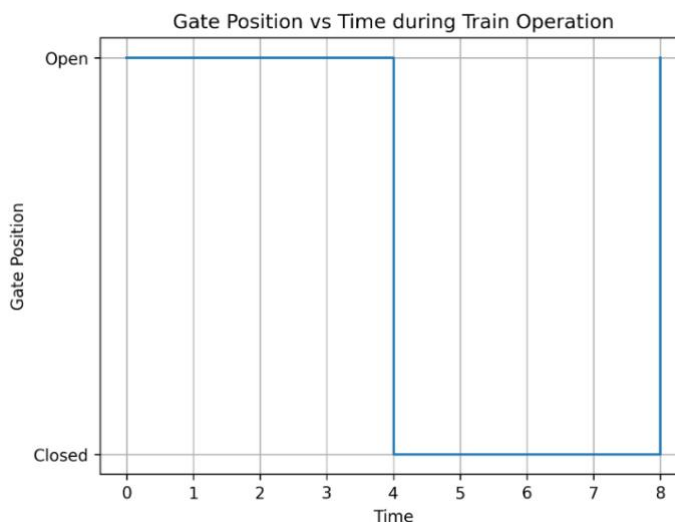

Fig. 3: Flowchart — System Working Process

5. Graph



6. Results and Discussion

The proposed system was tested under different conditions and showed reliable performance. The RF communication ensured timely signal transmission between train and gate units. The gate responded quickly to incoming signals, reducing delay. The obstacle detection mechanism successfully prevented gate closure when an object was detected. Overall, the system demonstrated efficient and safe operation.

7. Conclusion

The wireless railway gate control system provides a reliable and cost-effective solution for automating railway crossings. It reduces human intervention and minimizes accidents through timely gate control and obstacle detection. The system can be further enhanced by integrating IoT technologies and real-time monitoring systems.

8. Future Scope

- Integration with IoT for real-time monitoring
- GPS-based train tracking
- GSM alerts for users
- AI-based obstacle detection

8. References

- 1] S. S. Raut and M. R. Dhage, "Automatic Railway Gate Control System Using Microcontroller," *International Journal of Engineering Research & Technology (IJERT)*, vol. 3, no. 4, pp. 1–4, Apr. 2014.
- [2] K. R. S. Prasad, G. V. N. Reddy, and B. S. Kumar, "Automatic Railway Gate Control Using Embedded System," *International Journal of Innovative Technology and Exploring Engineering (IJITEE)*, vol. 2, no. 3, pp. 45–49, Feb.

2015

- [3] P. S. Borkar and A. A. Raut, “Intelligent Railway Gate Control System Using Ultrasonic Sensors,” *International Journal of Advanced Research in Electrical, Electronics and Instrumentation Engineering*, vol. 5, no. 6, pp. 5000–5005, Jun. 2016.
- [4] A. K. Mittal and B. Bhushan, “Wireless Communication Based Train Control System,” *International Journal of Computer Applications*, vol. 95, no. 10, pp. 20–24, Jun. 2014.
- [5] M. A. Mazidi, J. G. Mazidi, and R. D. McKinlay, *The 8051 Microcontroller and Embedded Systems*, 2nd ed. Upper Saddle River, NJ, USA: Pearson, 2007.
- [6] Muhammad Ali Mazidi, *The AVR Microcontroller and Embedded Systems*, 1st ed. Upper Saddle River, NJ, USA: Pearson, 2010.
- [7] IEEE, “IEEE Standard for Wireless Communication,” IEEE Std 802.15.4, 2011.